

How's that working for you???

HURF Swap Update



Patrick Stone, ADOT Program/Project Funding Administrator
October, 25, 2018

Presentation Overview

- ▶ Introductions
- ▶ HURFstory
- ▶ Show me the money...
- ▶ HURFX 2.0
 - Overview
 - Resources
 - How it is going so far
- ▶ Panel Discussion with Questions & Answers



HURFstory

- HURF Exchange:
 - Created by Legislature in 1997 and targeted to rural cities, towns, and counties
 - Authorized ADOT to provide State Highway Funds (SHF) in exchange for federal aid; only legal use of SHF on local projects
 - Established minimum exchange rate of 90¢/\$1
 - Projects must be on federal aid system (no local roads)
- Primarily used for construction phase
- Suspended in 2009 after recession as ADOT could no longer afford the program
- Federal aid:
 - Lots of strings attached - takes longer and costs more to build projects
 - Very challenging for small project sponsors
 - ADOT can quickly and easily deploy fed aid



HURFstory – the Prequels...

Historic HURF Exchange Projects By Region, 1998-2009

COG/MPO*	Total HURF Exchange \$ Paid Out	# of Projects	Average Project Size (\$)
CAG	11,493,081.45	38	302,449.51
CYMPO	1,316,373.00	2	658,186.50
FMPO	2,006,459.28	5	401,291.86
MAG	320,394.43	1	320,394.43
NACOG	18,953,257.13	40	473,831.43
PAG	26,419,484.18	13	2,032,268.01
SEAGO	9,982,072.90	5	1,996,414.58
WACOG	13,102,205.06	31	422,651.78
YMPO	7,561,414.52	10	756,141.45
Total	\$ 91,154,741.95	145	\$ 628,653.39

*COG = Councils of Government; MPO = Metropolitan Planning Organization. These regional planning entities are responsible for programming transportation projects in their area.

Show me the money...

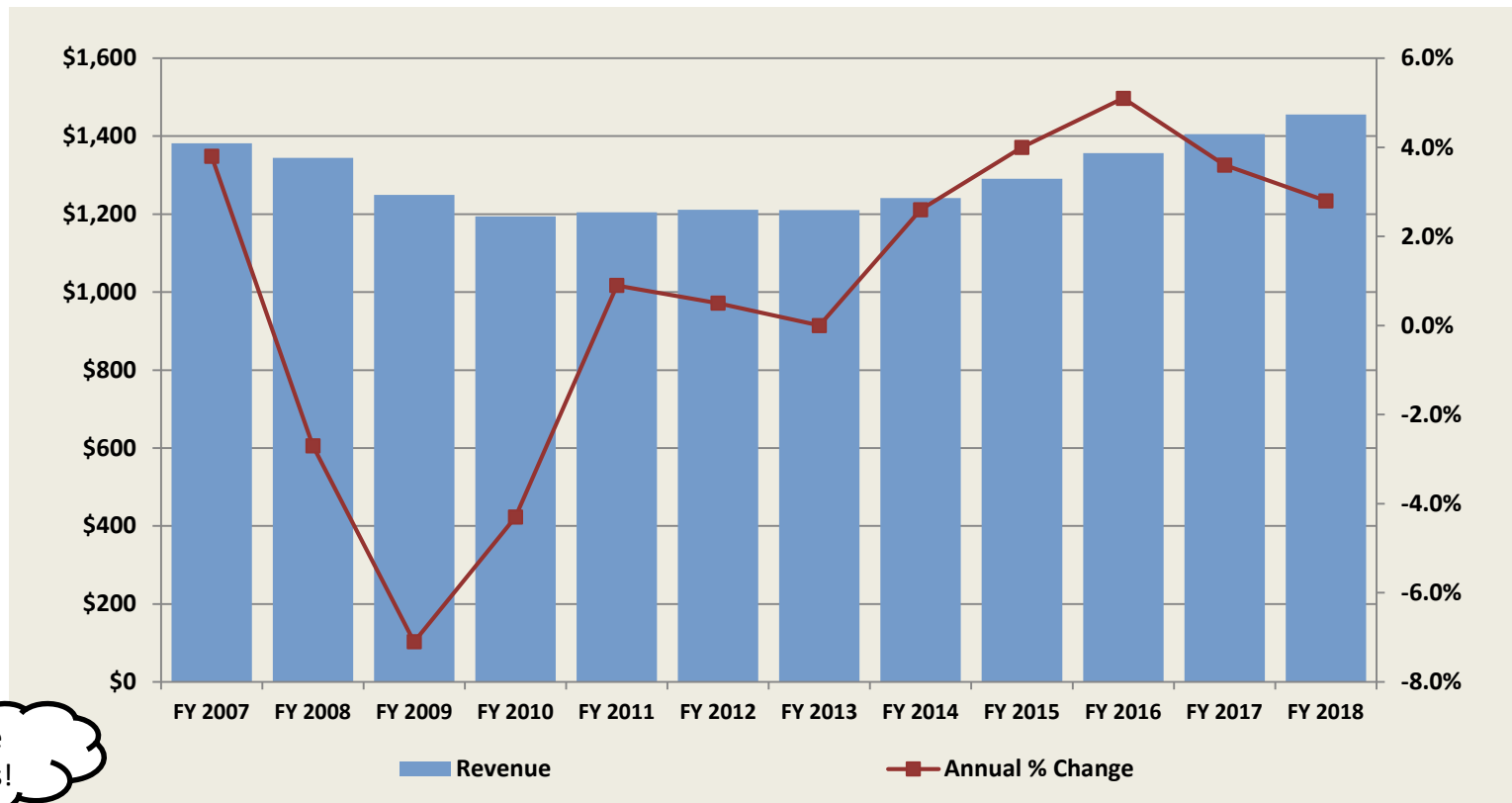

I love charts!



HURF Revenues and Annual % Change FY 07 – 18

Show me the money...

ARIZONA DEPARTMENT OF TRANSPORTATION FY 2018 HURF ACTUAL REVENUE DISTRIBUTION FLOW (Millions of Dollars)

NOTES:

- /1. Arizona Revised Statutes 28-5926 and 28-5927 transfer 1.6 percent of gas tax revenues to the State Lake Improvement Fund (SLIF) and 0.55 percent of gas tax revenues to the Off-Highway Vehicle Recreation Fund (OHVRF). The \$527.4 million of gas tax revenue is before of a total \$11.3 million transferred to the above two funds.
- /2. In FY 2018, \$656,100 was appropriated to MVD for the vehicle registration enforcement and 3rd party programs.
- /3. The \$99.4 million appropriation to DPS in FY 2018 has been netted of a \$0.1 million reversion from DPS to HURF for unused FY 2017 appropriations.
- /4. Starting in FY 2015, special off-the-top distributions to cities, towns and counties have been made each fiscal year. Laws 2016, 2nd Regular Session, Chapter 125 (HB 2708) distributes \$30.0 million to cities, towns and counties in FY 2018. Actual FY 2018 distributions: 1. Cities over 300,000 persons - \$1.6 million, 2. Cities/Towns - \$14.4 million, 3. Counties over 800,000 persons - \$4.0 million, 4. Counties - \$10.0 million. Counties over 800,000 persons distribution was deposited into the MAG and PAG 12.6% accounts within the State Highway Fund.
- /5. Laws 2011, 1st Regular Session, Chapter 28 (SB 1616) transfers from the State Highway Fund share of VLT generated the difference in the two-year and five-year VLT to the state general fund which totaled \$1.8 million. Laws 2010, 7th Special Session, Chapter 12 (HB 2012) an amount equal to 90 percent of the fees collected under 28-4802 (A) and 60 percent of the fees collected under 28-4802 (B) shall be transferred from the State Highway Fund share of VLT to the State General Fund which totaled \$6.3 million.
- /6. Per Arizona Revised Statutes 28-5808, 1.51 percent of the State Highway Fund share of HURF VLT is distributed to the DPS Parity Compensation Fund.
- /7. The 12.6% (statutory) and 2.6% (non-statutory) allocations from the State Highway Fund share of HURF distributions.
- /8. Revenues to the State Highway Fund are reduced by the amount retained by Authorized Third Parties for the collection of VLT.

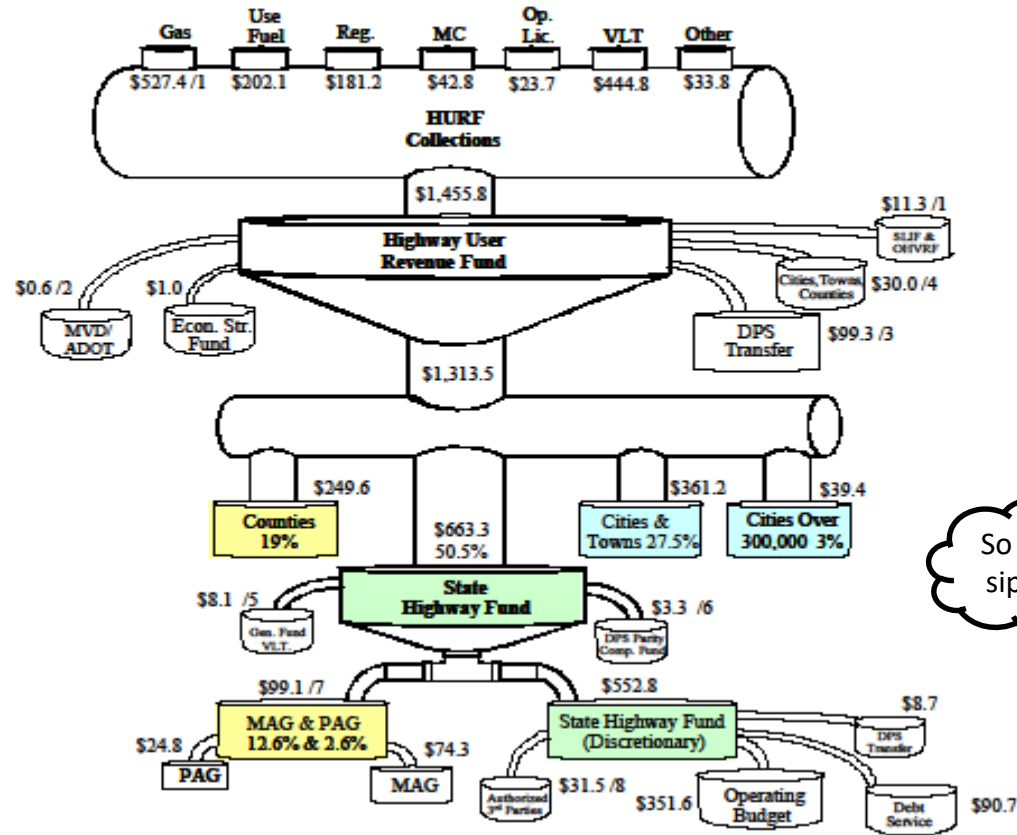

So many siphons



HURFX 2.0 - Overview

- Effective – October 1st, 2017
- New ADOT policy FIN 5.01 - establishes a clear expectation of timely project delivery
- Handled like any other project:
 - Same deadlines and processes (IGAs, finance authorization, final voucher, etc.)
 - Standardized IGA and project forms
- HOWEVER:
 - 90% of the funding is paid to the project sponsor in advance of expenditures being incurred; final 10% is reimbursed.
 - New HURF Exchange subfund established within SHF (DT2030)
- Amount available for the next five years is determined annually in conjunction with the development of the ADOT 5-year program, current amount is \$15.9 million
- Limited to discretionary federal aid only (Under 200K and Under 5K STBGP population only)
- Swap rate remains 90¢/\$1
- COG/MPO ledgers reflect all HURF Exchange transactions

HURFX 2.0 - Overview

- Current policies and procedures used for FA projects apply to HURF Exchange:
 - Loans/transfers by March 31st
 - Authorization requests submitted by May 15th
 - Use or lose by June 30th
 - Inactive projects
- ADOT can suspend the program if SHF revenues decline due to appropriations, transfers or special distributions
- ADOT can choose not to engage in a HURF Exchange in cases of misuse of, or failure to repay, HURF Exchange funding
- Tribal entities are not eligible as direct recipients of HURF Exchange funding, but can work with eligible sponsors
- Subject to risks associated with the State Highway Fund:
 - Fund sweeps, appropriation, transfer and distributions
 - HURF revenue performance, changes in economy
 - Timely and continuous receipt of federal reimbursements
 - Significant changes in federal aid or pro rata match requirements
- Loss of federal aid project delivery knowledge and experience in local agencies

HURFX 2.0 - Resources

- ADOT HURF Exchange website [HURF Exchange Program](#)
 - ADOT HURF Exchange Policy – FIN 5.01
 - HURF Exchange IGA template
 - Frequently Asked Questions
 - Forms
- ADOT Federal Aid Highway Program website: [Federal Aid Highway Program](#)
 - COG/MPO Federal Formula Funding Ledgers
- Functional Classification Maps: [Functional Classification Maps](#)
- Inactive Projects: [Inactive Projects](#)



HURFX 2.0 – How's it going so far???

- Have authorized 6 projects to date, totaling \$2.7 million
 - 1st project was for Town of Eloy
 - 4 requests for design, 2 requests for construction
 - 2 requests each for NACOG, SCMPO and YMPO
- Anticipating 11 project requests during Federal Fiscal Year 2019, totaling \$6.7m
- Successes:
 - Able to process funding authorizations within one week
 - Reimbursement requests to locals are processed at same time as funding authorization, much faster than before
 - Less administrative burden on ADOT and FHWA
- Challenges:
 - IGAs are taking longer than anticipated
 - Feedback on forms – formula errors, ease of use

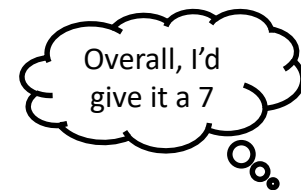



I'm curious about..

I have a question



Panel Discussion – Questions and Answers

I'm wondering why...



Over Here

